

**NATIONAL COIR RESEARCH AND MANAGEMENT INSTITUTE (NCRMI)
THIRUVANANTHAPURAM**

TENDER NOTICE

No. NCRMI/R&D/2012/ER01 /14

25/08/14

Sealed competitive tenders are invited from competent/firm/suppliers for the supply of Die plates and 10 set of Moulded Components. Tender form and detailed specification can be downloaded from the website www.ncrmi.org .The last date of submission of tender shall be 01.09.2014, 2.00 PM, for more details contact Ph.0471 2730788, Mob.9895989796

Director
NCRMI



**NATIONAL COIR RESEARCH & MANAGEMENT
INSTITUTE (NCRMI)**

Kudappanakkunnu P.O, Thiruvananthapuram –43
Tel/Fax:-0471-2730788 e-mail : ncrmikerala@gmail.com

No. NCRMI/R&D/2012/ER01/14

25.08.2014

TENDER

**Containing General Conditions and Schedule for the
Supply of die plates and 10 set of plastic molded components as per drawing**

Tender form issued to M/s.....
.....
.....
.....
.....

EARNEST MONEY DEPOSIT (EMD) : 2.5% of the total quoted amount.

Last Date for submission of Tender : 01.09.2014 – 2 PM

Date of Tender opening : 01.09.2014 – 2.30 PM

Cost of original/copy – Rs. 600/ + 5% VAT

**NATIONAL COIR RESEARCH AND MANAGEMENT INSTITUTE (NCRMI)
THIRUVANANTHAPURAM**

TENDER NOTICE

No. NCRMI/R&D/2012/ER01/14

25.09.2014

National Coir Research and Management Institute invites sealed competitive tenders from competent Manufactures/firms for the Supply of die plates and 10 no.s of sample molds in ABS plastic as per the drawing.

The tender forms and detailed specifications can be downloaded from the website www.ncrmi.org. The cost of the tender form is Rs. 600+ 5% VAT. It can be remitted by Demand Draft from any nationalized bank drawn in favour of the Director, NCRMI and can be submitted along with the tender. Cheque will not be accepted.

Last date for submission of Tenders is 01.09.2014, 2 PM. The tenders will be opened on 01.09.2014, 2.30 PM in the presence of Tenderers or their representatives if any present. The EMD of the Tender is 2.5% of the quoted amount and the selected company will be required to deposit an amount equal to 5% of the total amount as security in favour of the undersigned.

The Director, NCRMI reserves the right to accept or reject any or all the Tenders without assigning any reason what so ever.

**Director
NCRMI**

FORM OF TENDER

Sir,

I/We hereby tender to supply, under the annexed general conditions of contract, the whole of the articles referred to and described in the attached Specification and schedule, or any portion thereof as may be decided by the National Coir Research and Management Institute, at the rates quoted against each item. The articles will be delivered within the time and at the places specified in the schedule.

*I/We, am/are remitting/have separately remitted 2.5% of the total quoted amount as earnest money.

Yours faithfully,

(Signature)

(Address)

.....

Date :.....

* To be scored off in cases where no earnest money deposit is furnished.

INTRODUCTION

NCRMI an organization spearheading various R&D projects in the traditional segment of Coir was established in 1994, under the name C-DOCT to cater the varied needs of coir sector of Kerala. It is registered under the Travancore-Cochin Literary Scientific and Charitable Societies Act 1956. NCRMI have been conducting studies for the development of new coir technologies in collaboration with similar research organizations across the country and even at the International level.

As part of the infrastructure development to enable the institute to take up more Research and Development activities on coir machineries, NCRMI established an engineering workshop and allied facilities. NCRMI planning to procure the Fork Lift. The specification and features etc. are narrated in detail in this schedule.

REQUIREMENT AND SPECIFICATION

Requirement and Specification of 3 type of Dies and 10 set mold is annexed as Drawings

GENERAL CONDITIONS

1. The tender should be addressed to the Director, NCRMI in a sealed cover shall be accepted in the NCRMI office at Kudappanakkunnu up to 2 PM on September 01st 2014 and shall be opened at 2.30 PM on the same day.
2. The tender should be in the prescribed form which can be obtained from the officer mentioned in the tender notification on payment of the price noted therein. The cost of tender forms once paid will not be refunded. Tenders which are not in the prescribed form are liable to be rejected.
3. Intending tenderers should send their tenders so as to reach the officer mentioned in the tender notification, on due date and time noted therein. No tender received after the specified date and time will be accepted on any account. The rates will be considered firm for acceptance till the date mentioned therein. Tenders not stipulating period of firmness and tenders with price variation clause and/or 'subject to prior sale' condition are liable to be rejected.
4. (a) Every tenderer who has not registered his name with the State Government (Stores Purchase Department), should send along with his tender, an earnest money of 2.5 % of total quoted amount. The amount may be paid by Demand Drafts (crossed) on the local branch of State Bank of Travancore/ State Bank of India drawn in favour of the Director, NCRMI. Cheques will not be accepted. The earnest money of unsuccessful tenderers will be returned as soon as possible

after the tenders are settled; but that of the successful tenderers will be adjusted towards the security that will have to be deposited for the satisfactory fulfillment of the contract. No interest will be paid for the earnest money deposited.

(b) Tenderers whose names are registered with Government (Stores Purchase Department) are generally exempted from furnishing earnest money for such articles for which they have registered their names. If they tender for stores other than those for which they have registered their names, they will have to furnish earnest money as in the case of unregistered firms. Registered firms will have to quote invariably in every tender they submit, the registration number assigned to them by the Stores Purchase Department. Attested copy of registration certificate may be enclosed with the tender for reference.

(c) (i) Small Scale Industries and Cottage Industries within the Kerala state, which are certified as such by the Director of Industries and Commerce or by the Regional Joint Director of Industries and Commerce will be exempted from furnishing earnest money against tenders and security deposit against contracts for supply of stores manufactured by them. In respect of security deposit the soundness and reliability of the concerns to undertake the contract should be certified by the Director of Industries and Commerce or by the Regional Joint Director of Industries and Commerce.

5. The tenders will be opened on the appointed day and time in the office of the Director, NCRMI, in the presence of such of those tenderers or their nominees who may be present at that time.
6. If any tenderer withdraws from his tender before the expiry of the period fixed for keeping the rates firm for acceptance, the earnest money, if any deposited by him will be forfeited to National Coir Research and Management Institute or such action taken against him as the Institute think fit.
7. Tenderers shall invariably specify in their tenders the delivery conditions including the time required for the supply of articles tendered for.
8. (a) The tenderers shall clearly specify whether the articles offered bear Indian Standards Institution Certification Mark or not. In such cases, they shall produce copies of certification marks along with their tender in support of it.

(b) Tenderers shall clearly specify whether the goods are offered from indigenous sources, from imported stocks in India or from foreign sources to be imported under a license.
9. The final acceptance of the tenders rests entirely with the National Coir Research and Management Institute who do not bind themselves to accept the lowest or any tender. But the tenderers on their part should be prepared to

carry out such portion of the supplies included in their tender as may be allotted to them.

10. In the case of materials of technical nature, the successful tenderer should be prepared to guarantee satisfactory performance for a definite period under a definite penalty.
11. Communication of acceptance of the tender normally constitutes a concluded contract. Nevertheless the successful tenderer shall also execute an agreement for the due fulfillment of the contract within the period specified in the letter of acceptance. The contractor shall have to pay all stamp duty/lawyer's charges and other expenses incidental to the execution of the agreement. Failure to execute the agreement within the period specified will entail the penalties set out in Para below.
12. (a) The successful tenderer shall, before signing the agreement, and within the period specified in the letter of acceptance of this tender, deposit a sum equivalent to 5 per cent of the value of the contract as security for the satisfactory fulfillment of the contract. The amount of EMD deposited along with the tender can be adjusted and balance amount to be remitted towards security. The amount of security may be deposited in the manner prescribed in Clause 4 supra or in fixed Deposit Receipt of State Bank of Travancore/State Bank of India, endorsed in favour of Director, NCRMI. Letter of guarantee in the prescribed form for the amount of security from an approved Bank will also be considered enough at the discretion of the Institute. If the successful tenderer fails to deposit the security and execute the agreement as stated above, the earnest money deposited by him will be forfeited to the Institute, and the contract arranged elsewhere at the defaulter's risk and any loss incurred by the Institute on account of the purchase will be recovered from the defaulter who will, however not be entitled to any gain accruing thereby. If the defaulting firm is a registered firm, their registration is liable to be cancelled.

(b) In cases where a successful tenderer, after having made partial supplies, fails to fulfill the contracts in full, all or any of the materials not supplied may at the discretion of the Director, NCRMI, be purchased by means of another tender/quotation or by negotiation or from the next higher tenderer who had offered to supply already and the loss, if any, caused to the Institute shall thereby, together with such sums as may be fixed by the Institute towards damages, be recovered from the defaulting tenderer.

(c) Even in cases where no alternate purchases are arranged for the materials not supplied, the proportionate portion of the security deposit based on the cost of the materials not supplied at the rate shown in the tender of the defaulter shall be forfeited and balance alone shall be refunded.

13. The security deposit shall, subject to the conditions specified herein, be returned to the contractor within one year after the expiration of the contract, but in the event of any dispute arising between the Institute and the contractor, the Institute shall be entitled to deduct out of the deposit or the balance thereof, until such dispute is determined, the amount of such damages, costs, charges and expenses as may be claimed. The same may also be deducted from any other sum which may be due to any time from the Institute to the contractor. In all cases where there are guarantee for the goods supplied, the security deposit will be released only after the expiry of the guarantee period.
14. All payments to the contractor will be made by the Director, NCRMI in due course:-
 - i) by cheques.
 - ii) All incidental expenses incurred by the Institute for making payments outside the district in which the claim arises shall be borne by the contractor.
15. The tenderers shall quote also the percentage of discount offered by them in case the payment is made promptly within fifteen days/within one month of taking delivery of stores.
16. Ordinarily payments will be made only after the supplies are actually verified and taken to stock but in exceptional cases, payments against satisfactory shipping documents including Certificates of Insurance will be made up to 90 percent of the value of the materials at the discretion of the Institute. Bank charges incurred in connection with payment against documents through Bank will be to the account of the contractor. The firms shall produce stamped pre receipted invoices in all cases where payments (advance/final) for release of railway receipts/shipping documents are made through banks. In exceptional cases where the stamped receipts of the firms are not received for the payments (in advance), the unstamped receipt of the bank (i.e. counterfoils of pay-in-slips issued by the Bank) alone may be accepted as a valid proof for the payment made.
17. The contractor shall not assign or make over the contract or the benefits or burdens thereof to any other person or body corporate. The contractor shall not underlet or sublet to any person or persons or body corporate the execution of the contract or any part thereof without the consent in writing of the Director, NCRMI who shall have absolute power to refuse such consent or to rescind such content (if given) at any time if he is not satisfied with the manner in which the contract is being executed and no allowance or compensation shall be made to the contractor or the sub-contractor upon such rescission. Provided always that is such consent be

given at any time, the contractor shall not be relieved from any obligation, duty or responsibility under this contract.

18. (a) In case the contractor becomes insolvent or goes into liquidation, or makes or proposes to make any assignment for the benefit of his creditors or proposes any composition with his creditors for the settlements of his creditors for the settlement of his debts, or carries on his business or the contract under inspection on behalf of his creditors or in any case receiving order or orders, for the administration of his estate are made against him, or in case the contractor shall commit any act of insolvency or in case in which under any clause or clauses of his contract the contractor shall have rendered himself liable to damages amounting to the whole of his security deposits: the contract shall there upon, after notice given by the Director, NCRMI to the contractor, be determined and the Institute may complete the contract in such time and manner and by such persons as the Institute shall think fit. But such determination of the contract shall be without any prejudice to any right or remedy of the Institute against the contractor or his sureties in respect of any breach of contract therefore committed by the contractor. All expenses and damages caused to the Institute by any breach of contract by the contractor shall be paid by the contractor to the Institute and may be recovered from him under the provisions of the Revenue Recovery Act in force in the State.
19. (a) In case the contractor fails to supply and deliver any of the said articles and things within the time provided for delivery of the same, or in case the contractor commits any breach of any of the covenants, stipulations and agreements herein contained, and on his part to be observed and performed, then and in any such case, it shall be lawful for Institute(if they shall think fit to do so) to arrange for the purchase of the said articles and things from elsewhere or on behalf of the Institute by and order in writing under the hand of the Director, NCRMI put an end to this contract and in case the Institute shall have incurred, sustained or been put to any costs, damages or expenses by reason of such purchase or by reason of this contract having been so put an end to or in case any difference in price, compensation, loss, costs, damages and expenses or other moneys shall then or any time during the continuance of this contract be payable by the contractor to the Institute under and by virtue of this contract, it is shall be lawful for the Institute from and out of any moneys for the time being payable or owing to the contractor from the Institute under or by virtue of this contractor otherwise, to pay and reimburse to the Institute all such costs, damages and expenses they may have sustained incurred or been put to by reason of the purchase made elsewhere or by reason of this contract having been so put an end to as aforesaid and also all such differences in price, compensation, loss, costs, damages, expenses and other moneys as shall for the time being be payable by the contractor aforesaid.
- (b) In case any difference or dispute arises in connection with the contract, all legal proceedings relating to the matter shall be instituted in the Court within whose jurisdiction the Director, NCRMI voluntarily resides.

20. Any sum of money due and payable to the contractor (including security deposit returnable to him) under the contract may be appropriated by the Director, NCRMI or the Institute or any other person authorized by the Institute and set off against any claim of the Director, NCRMI or the Institute for the payment of a sum of money arising out of or under any other contract made by the contractor with the Director, NCRMI or the Institute or any other person authorized by the Institute. Any sum of money due and payable to the successful tenderer or contractor from the Institute shall be adjusted against any sum of money due to the Institute from him under any other contracts.
21. Every notice thereby required or authorized to be given may be either give to the contractor personally or left at his residence or last known place or abode or business, or may be handed over to his agent personally, or may be addressed to the contractor by post at his usual or last known place of abode or business and if so addressed and posed, shall be deemed to have been served on the contractor on the date on which, in the ordinary course of post a letter so addressed and posted would reach his place of abode or business.
22. The tenderer shall undertake to supply materials according to the standard sample and/or specifications.
23. (a) No representation for enhancement of rates once accepted will be considered.

(b)In the case of imported goods, when the price accepted is the ex-site price quoted by the tenderer, the benefit of any reduction in the c.i.f. price should accrue to the Institute.
24. Any attempt on the part of the tenderers or their agents to influence the Institute in their favour by personal canvassing with the officers concerned will disqualify the tenderers.
25. Tenderers should be prepared to accept orders subject to the penalty clause for forfeiture of security in the event of default in supplies or failure to supply within the stipulated period.
26. Samples would be forwarded if called for and unapproved samples got back by the tenderers at their own cost. Samples sent by V.P. Post for 'freight to pay' will not be accepted. The approved samples may or may not be returned at the discretion of the undersigned. Samples sent by post, railway or plane should be so despatched so as to reach the Director, NCRMI no later than the date on which the tenders are due. In the case of samples sent by railway the receipt should be sent separately

and not along with the tender since the tender will be opened only on the appointed day and demurrage will have to be paid if the railway parcels are not cleared in time. The Institute will not be responsible if

any sample is found missing at any time due to the non-observance of the provisions of this clause. Tenderers whose samples are received late will not be considered. Samples should be forwarded under separate cover duly listed and the corresponding number of the item in the tender schedule should also be noted in the list of samples. Tenders for the supply of materials are liable to be rejected unless samples if called for, of the materials tendered for are forwarded.

27. Telegraphic quotations will not be considered unless they give details of prices and are immediately followed by confirmation with full relevant details posted before the due date of tender.

28. (a) The price quoted should be inclusive of all taxes, duties, cesses, etc., which are or may become payable by the contractor under existing or future laws or rules of the country of origin/supply or delivery during the course of execution of the contract.

(b) In case payment of customs/excise duty is to be made by the Director, NCRMI the Director, NCRMI will pay the duty on the "unloaded invoice price" only in the first instance, any difference being paid when the tenderer produces the final assessment orders later.

29. The tenderer will invariably furnish the following certificates with their bills for payment.

"Certified that the goods on which sales tax has been charged have not been exempted under the Central Sales Tax Act or the State Sales Tax Act or the Rule made there under and the charges on account of Sales Tax on these goods are correct under the provisions of the relevant act or the rules made there under. Certified further that we (or our Branch or Agent)

.....
.....

..... (Address) are registered as dealers in the State of under Registration No. for the purpose of Sales Tax".

30. Final payments will be made only on production by tenderers the tax clearance certificates relating to Agricultural Income Tax, Sales Tax and Income Tax;

31. Special conditions, if any, of the tenderers attached with the tender will not be applicable to the contract unless they are expressly accepted in writing by the purchaser.
32. The successful tenderer should send an agreement executed and signed in Kerala stamp paper worth Rs.100/- before awarding the work. A specimen form of agreement is given as annexure-I to this tender.
33. The Director, NCRMI reserves the right to accept in full/part or reject the tender without assigning any reasons thereof.

DIRECTOR
NCRMI

Thiruvananthapuram
25-08-2014

ANNEXURE-I

AGREEMENT

Articles of agreement executed on this the day of
..... between the Director, National Coir
Research and Management Institute (hereinafter referred to as “Director, NCRMI”)
on the one part

and

Shri..... (H.E.
name and address of the tenderer) (hereinafter referred to as “the bounden” on the other
part.

WHEREAS in response to the notification No. dated bounden
has submitted to the Institute a tender for the specified
therein subject to the terms and conditions contained in the said tender;

WHEREAS the bounden has also deposited with the Institute a sum of Rs.....
as earnest money for the execution of an agreement undertaking the due fulfillment of
the contract in case his tender is accepted by the Institute.

NOW THESE PRESENTS WITNESS and it is hereby mutually agreed as follows:

1. In case the tender submitted by the bounden is accepted by the Institute and the
contract for is awarded to the bounden, the bounder shall
within days of acceptance of his tender, execute an agreement with the
Institute incorporating al the terms and conditions under which the institute accepts his
tender.

2. In case the bounden fails to execute the agreement as aforesaid incorporating the terms
and conditions governing the contract the Institute shall have power and authority to
recover from the bounden any loss or damage caused to the Institute by such breach as
may be determined by the Institute by appropriating the earnest money deposited by the
bounden and if the earnest money is found to be inadequate the deficit amount may be
recovered from the bounden and his properties movable and immovable in the manner
hereinafter contained.

3. All sums found due to the Institute under by virtue of this agreement shall be
recoverable from the bounden and his properties movable and immovable under the
provisions of the Revenue Recovery Act for the time being in force as though such sums
are arrears of land revenue and in such other manner the Institute may deem fit. In witness
whereof Shri.(H.E. name and
designation) for and on behalf of the Director, National Coir Research and

Management Institute and Shri..... the bounden have hereunto set their hands the day and year shown against their respective signatures.

Signed by Shri. (date) in the presence of witnesses:

1.

2.

Signed by Shri (date) in the presence of witnesses:

1.

2.

ANNEXURE-II

Die Specifications

Die Plate Material	: D2
All Other Plate Material	: MS
Pilot Pins, Guide pins, Screws	: Use standard Parts
Machining Method	: CNC or EDM at Special Profiles, Conventional machining at rest areas
Hardness	: 50 HRC at Mold Area
Mold area Finish	: Matt Finish
Tolerance	: As per Drawings attached

Component Specifications

Mold Material	: ABS
Surface Finish	: Matt Finish
Color of Component	: Wine Red
Qty	: 10 no.s

DIRECTOR
NCRMI

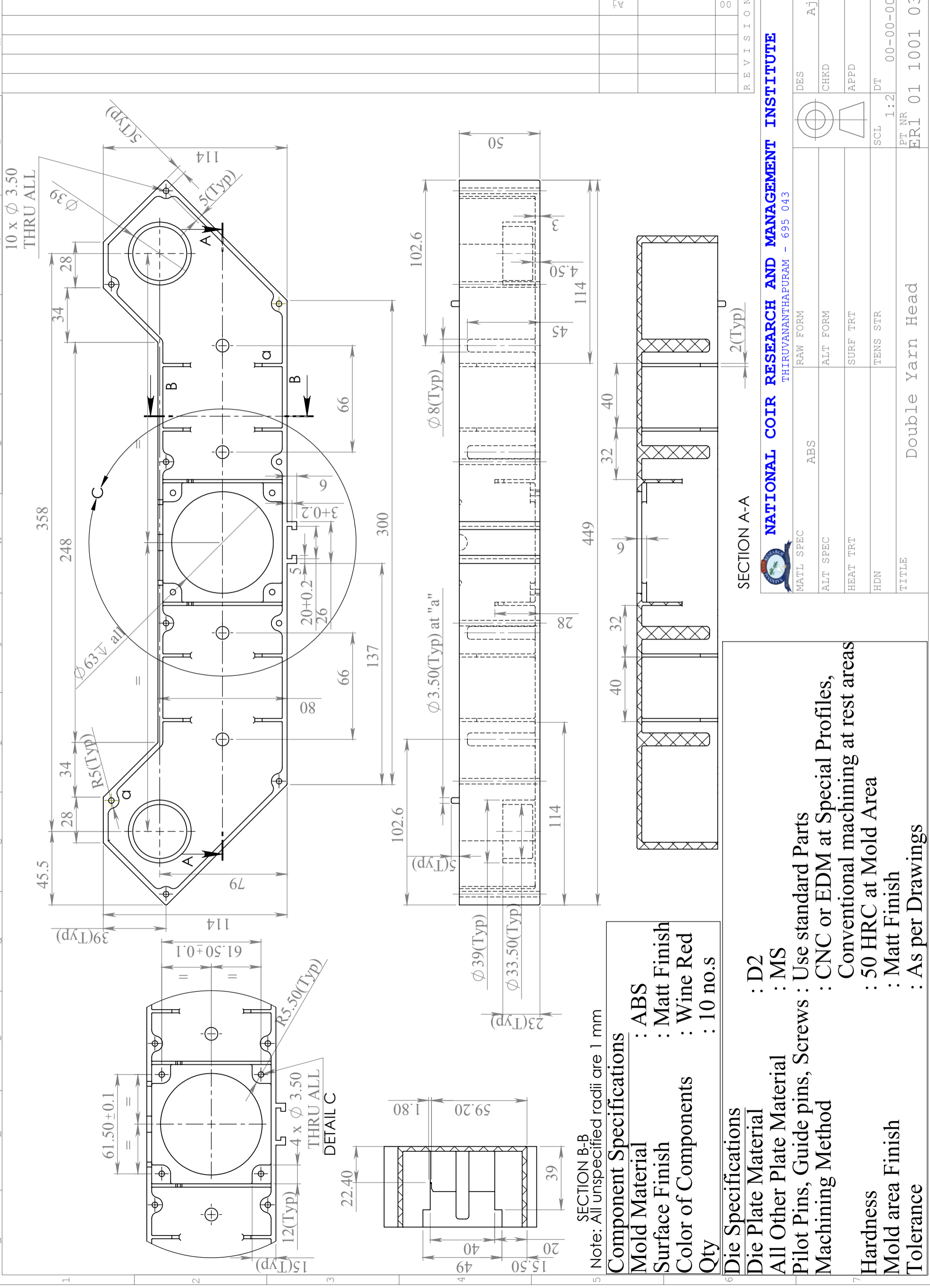

SECTION B-B
Note: All unspecified radii are 1 mm

Component Specifications
 Mold Material : ABS
 Surface Finish : Matt Finish
 Color of Components : Wine Red
 Qty : 10 no.s

Die Specifications
 Die Plate Material : D2
 All Other Plate Material : MS
 Pilot Pins, Guide pins, Screws : Use standard Parts
 Machining Method : CNC or EDM at Special Profiles,
 Conventional machining at rest areas
 Hardness : 50 HRC at Mold Area
 Mold area Finish : Matt Finish
 Tolerance : As per Drawings

SECTION A-A

MATL SPEC	RAW FORM	DES	00
ALT SPEC	ALT FORM	CHKD	
HEAT TRT	SURF TRT	APPD	
HDN	TENS STR	SCL	1:2
TITLE	Double Yarn Head		
		PT NR	00-00-00
		ER1	01 1001 03

NATIONAL COIR RESEARCH AND MANAGEMENT INSTITUTE
 THIRUVANANTHAPURAM - 695 043

REVISION	

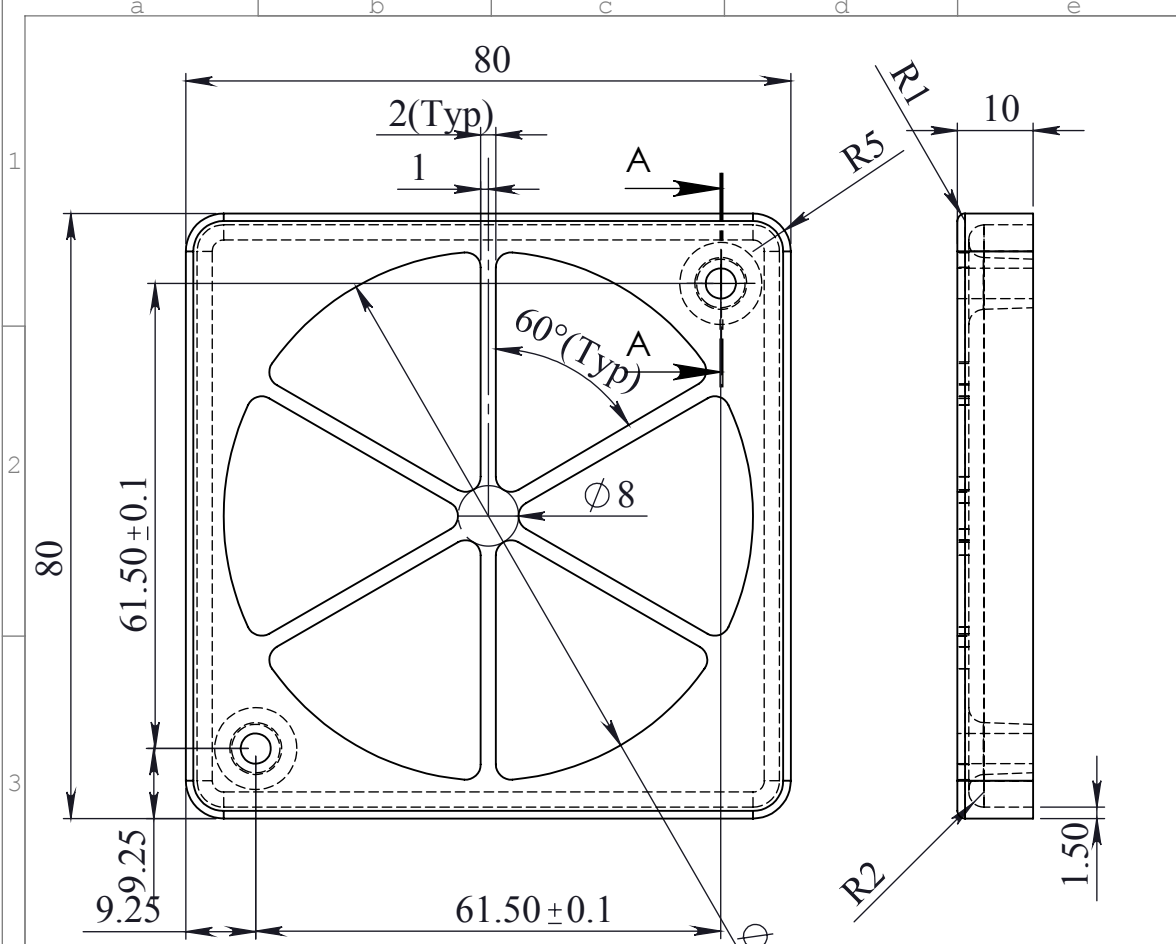

Note: All unspecified radii are 1 mm

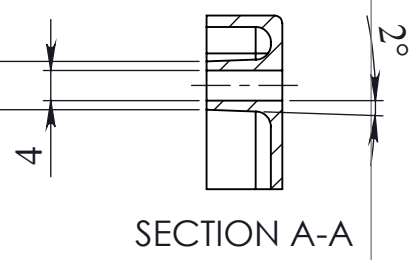
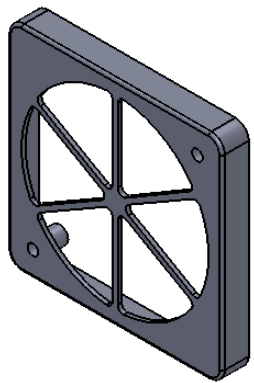

Component Specifications	
Mold Material	: ABS
Surface Finish	: Matt Finish
Color of Components	: Wine Red
Qty	: 10 no.s

Die Specifications	
Die Plate Material	: D2
All Other Plate Material	: MS
Pilot Pins, Guide pins, Screws	: Use standard Parts
Machining Method	: CNC or EDM at Special Profiles, Conventional machining at rest areas
Hardness	: 50 HRC at Mold Area
Mold area Finish	: Matt Finish
Tolerance	: As per Drawings

REVISION	
00	Aj



NATIONAL COIR RESEARCH AND MANAGEMENT INSTITUTE

THIRUVANANTHAPURAM - 695 043

MATL SPEC	ABS	RAW FORM		DES	Aj
ALT SPEC		ALT FORM		CHKD	
HEAT TRT		SURF TRT		QTY	0
HDN		TENS STR	SCL	DT	29/11/13
TITLE			PT NR		
Fan Cover			ER1 01 1003 03		